

HUMBOLDT-UNIVERSITÄT ZU BERLIN

— Institut für Physik —

---

**Experiment instructions for the advanced internship**

## **Measurement of the muon lifetime**

**Dr. Marzieh Bahmani**

**November 16, 2023**

**AG Experimental Elementary Particle Physics**

**Physiklabor 1, 2'424**

---

# 1 General preliminary remarks

The aim of this experiment is to determine the mean lifetime of the muon experimentally. This also includes learning basic practices in particle physics, i.e. handling particle detectors and the associated measurement electronics, and consistent statistical analysis and interpretation of the measurement results.

## 1.1 Implementation

The experiment is divided into two parts. On the first day of the experiment, the experimental setup, calibration, and the start of the measurement of the muon lifetime spectrum will be performed. The measurement runs overnight, but for at least 24 hours. On the second day of the experiment, the measurement is ended and the life of the muon is then determined by statistical analysis of the measurement data.

## 1.2 Previous knowledge

Fundamentals of elementary particle physics and the physics of particle detectors, but also electronics and statistics, are necessary prerequisites for successfully carrying out this experiment. **Please note that the given literature should be read before carrying out the experiment, especially with regard to the principle of the experiment, the data readout and the subsequent statistical analysis.** At the end of this section you will find a list of questions that should be used as a guide during preparation. At the beginning of first day there is a test; for the experimental setup, and the statistical analysis. In the test a basic understanding of the experiment as well as the necessary experimental and statistical methods must be demonstrated; otherwise the attempt may not be completed on the agreed date.

Furthermore, in section 1.4 there are special tasks that have to be completed before the start of the experiment. On the one hand, these serve to deepen the understanding of the experiment and, on the other hand, are necessary preparatory work for the implementation of the experiment. The solutions must be submitted in writing to the supervising assistant on the day of the experiment. Failure to complete the tasks also leads to the attempt being repeated.

The previous knowledge required in addition to these instructions can be found almost without exception in Leo's book LEO [1], which is available in the library (Schrödingerzentrum). The following list is intended to give a brief overview of the necessary basic knowledge as well as further literature.

- Properties of the muon, muon decay, law of decay, mean lifetime [5, 7]
- Cosmic radiation, shower formation, pion decay, passage of charged particles through matter, radiation length, energy loss through ionization, bremsstrahlung [1] chapter 1 and 2.
- Scintillators: Functionality, parameters, advantages and disadvantages, areas of application, structure and principle of photomultipliers, light guides (*light guides*) [1] chapter 7, 8 and 9[9, 6].
- Measuring electronics and logic circuits: measuring amplifiers, discriminator and coincidence circuits, time measurement (*time to amplitude converter*), Analog-to-digital converter (*single channel analyzer, multi channel analyzer, trigger*), BOOLSCHHE Algebra, signal transmission on cables, NIM and TTL standard in Ref [1] chapter 11, 12, 13 and 14.
- Basics of statistics, probability distributions, averaging, samples, histograms, hypothesis tests, parameter tests and

Maximum-Likelihood,  $\chi^2$ -Adaptation fit and interpretation, error calculation, statistical and systematic errors in Ref [1] chapter 4 [2, 4, 3, 11].

### 1.3 List of questions (exemplary)

#### 1.3.1 Muon decay

- Why do muons despite a comparatively short lifetime of approx  $2\ \mu\text{s}$  even reach to the ground? How is it possible to measure the lifetime of the muons within the detector system, even though they have already had a flight time that corresponds to several km?

#### 1.3.2 Detectors

- What forms of energy loss occur when charged particles pass through matter? How does the course of the BETHE-BLOCH- Curve depending on the LORENTZ- Boost  $\beta\gamma$  or from the momentum of the particle? Why does bremsstrahlung play no role for the muons considered in the energy domain? Explain the functional principle of the lead absorber that is used in the detector.
- How does a scintillator work? What is a wavelength shifter? How is the time resolution of the photomultiplier determined? What are the sources of noise?

#### 1.3.3 Switching electronics

- What voltage values are used to define logic signals in the FastNIM standard?

#### 1.3.4 Statistics

- What is a histogram? How do you calculate the expected value and variance within a channel ? What happens when several adjacent channels of the histogram are combined ( *rebinning*)?
- Explain the *maximum likelihood*? Explain its relation to the  $\chi^2$ - Parameter of fit. What are the requirements for using a  $\chi^2$ - Fits ? What is the expected value of that  $\chi^2$  per degree of freedom and why? How do you interpret the deviations from this expected value ?
- How do you calculate the statistical uncertainties of the results of a parameter of the fit?
- What is the systematic uncertainties of an experiment, and what options are there for handling them? Make the difference between the statistical and systematic uncertainties of a measurement clear.

### 1.4 Preparatory tasks

The following tasks must be completed before starting the experiment.

**Exercise 1.4a:** Calculate with the help of Eq. 9 the normalized probability density  $\rho(t)$  for the muon decay and show that  $\tau_\mu$  equal to the expected time value of  $\rho(t)$  is ( *average lifetime* of the muon in the ensemble).

**Exercise 1.4b:** Calculate the maximum energy of the muon decay  $e^\pm$  using energy or conservation of momentum. To do this, proceed as follows: First consider a general two-body decay  $A \rightarrow B + C$ . Write down the balance equation of the

four-momentum involved in the decay in the rest frame of particle A. On that basis, you show that for the energy  $E_B$  of particle B.

$$E_B = \frac{m_A^2 + m_B^2 - m_C^2}{2m_A}, \quad (1)$$

in which  $m_A, m_B, m_C$  are the masses of particles involved. Now trace the three-body decay of the muon back to a two-body decay by using the two neutral neutrinos to a two-particle system with  $E_{2\nu} = E_{\nu_\mu} + E_{\nu_e}$ ,  $\vec{p}_{2\nu} = \vec{p}_{\nu_\mu} + \vec{p}_{\nu_e}$ . Use equ 1 to find the pressure for the energy of the released electron. For which configuration of the outgoing decay particles the electron energy is maximal? Give a numerical value for this energy

**Exercise 1.4c:** What is the LORENTZ-BOOST  $\beta\gamma$  of a minimum ionising particle? What is the assigned momentum of (a) an electron, (b) muon and (c) a proton?

**Exercise 1.4d:** Roughly calculate the energy loss of a minimal ionizing particles when passing through 5 cm lead or 6 cm aluminum. For the sake of simplicity, assume that the energy loss does not change in the vicinity of the minimum.

**Exercise 1.4e:** For the circuit structure of the experiment, connector cables with lengths of 20 or 30 cm are available. Calculate the delay times of signals for the given cable lengths. All cables are of the RG58U type with an impedance of  $50\Omega$ . Are the delay times relevant for this experiment

**Exercise 1.4f:** All NIM-modules in this experiment are made so that the generated logic signals have a width of approx. 10 ns. What is the minimum delay time you expect for a single coincidence unit?

**Exercise 1.4g:** Consider the 3-fold coincidence within a circuit 5 with regard to your results from exercises 1.4e and 1.4f. Starting with the photomultipliers, draw a timing diagram for this part of the circuit. To what extent this circuit 5 need to be modified, and how do you implement this technically?

**Exercise 1.4h:** Write Eq. 14 in a more skilful form with regard to the parameter of fit in the evaluation.

## 2 Introduction

### 2.1 Electroweak theory and muon decay

The standard model of elementary particle physics indicates that there are three lepton families

$$\begin{pmatrix} \nu_e \\ e \end{pmatrix} \quad \begin{pmatrix} \nu_\mu \\ \mu \end{pmatrix} \quad \begin{pmatrix} \nu_\tau \\ \tau \end{pmatrix}, \quad (2)$$

as well as their antiparticles. The charged leptons  $e, \mu$  and  $\tau$  do not differ in the strength of their electromagnetic and weak interaction. [12]:

$$\begin{aligned} m_e &= 0.510\,998\,92(4) \text{ MeV}, \\ m_\mu &= 105.658\,369(9) \text{ MeV}, \\ m_\tau &= 1776.99^{+0.29}_{-0.26} \text{ MeV}. \end{aligned} \quad (3)$$

Both muons and taus are unstable:

$$\tau_\mu = 2.197\,03(4) \mu\text{s}, \quad \tau_\tau = 290.6(10) \text{ fs}. \quad (4)$$

In almost 100 % of all cases, muons decay weakly via the exchange of a W boson

$$\mu \xrightarrow{W} e \nu_e + \nu_\mu. \quad (5)$$

Higher order processes in which a photon also occurs in the final state are very rare. In the  $V-A$ - Theory the decay width of the muon in leading order (in the case of small momentum transfers compared to the mass of the W bosons):

$$\Gamma_{\mu \rightarrow e \nu_e \nu_\mu} = \frac{G_F^2 m_\mu^5}{192 \pi^3}. \quad (6)$$

The coupling constant is  $G_F$ . The FERMII- theory is related to the electroweak coupling constant  $g_W$  by

$$\frac{g_W^2}{8 M_W^2} = \frac{G_F}{\sqrt{2}}. \quad (7)$$

The probability of decay  $\Gamma$ , leads to a constant decay rate for muons ( N )

$$\Gamma = -\dot{N}/N, \quad (8)$$

The integration of this equation then gives

$$N(t) = N_0 e^{-t/\tau_\mu}, \quad (9)$$

in which  $\tau_\mu = 1/\Gamma$  and  $N(t)$  the number of surviving muons at the moment  $t$  mean. In this attempt, however, will not  $N(t)$  measured directly, but the number of decays of muons, which more or less randomly enter the detector system. The number of decays in the time interval  $t+dt$  results from differentiation of eq. (9)

$$-dN(t) = \frac{N_0}{\tau_\mu} e^{-t/\tau_\mu} dt. \quad (10)$$

### 2.1.1 Muonic Atoms and Nuclear Capture

It should be noted that negatively charged muons can form muonic atoms with the positively charged atomic nuclei of the material in which they are located and this affect the muon life

Material	$\Lambda_C [\mu s^{-1}]$	$Q$
Al	$0.7054 \pm 0.0013$	0.993
Cu	$5.676 \pm 0.037$	0.967
Pb	$13.45 \pm 0.18$	0.844

Table 1: Capture Rates and Huff- Factors for  $\mu^-$  in different core materials. [10]

time. Here is the  $\mu^-$ - captured by the Coulomb field of the nucleus and bound in the K-shell in a negligibly short period of time of less than 1 ns. The mean radius of this state is around the mass ratio of electron to muon ( $\sim 200$ ) which is smaller than electronic atoms, and leads to a strong overlap of the muon and nuclear wave functions. <sup>1</sup>There is therefore a possibility that the muon through the reaction  $\mu^- + p \rightarrow n + \nu_\mu$  is absorbed by the core, which competes with the free decay of the  $\mu^-$ . If the nucleus is captured by the weak interaction, the mean capture time is of the same order of magnitude as of the free muon decay and therefore leads to an effective, no longer negligible extension of the muon lifetime  $\tau_0$ :

$$\frac{1}{\tau_{\text{eff}}} = \frac{Q}{\tau_\mu} + \Lambda_C, \quad (11)$$

The capture rate values  $\Lambda_C$  and Huff- Factors  $Q$  of muons in different materials are given in Tab . 1 . The law of decay for muons (eq. 9) must be modified accordingly as:

$$N(t) = N_{\mu^+} \left( e^{-t/\tau_\mu} + \frac{1}{f} e^{-t/\tau_{\text{eff}}} \right), \quad (12)$$

<sup>1</sup>It is worth noting here that the probability of overlap depends on the atomic number  $Z$  of the surrounding medium  $\sim Z^4$  depends.

in which  $f$  indicates the ratio between positively and negatively charged muons. This is experimentally determined to [8]:

$$f = N_{\mu^+}/N_{\mu^-} = 1.270(3). \quad (13)$$

Analogous to eq. 10 which is obtained for the number of decays in time interval  $t+dt$ :

$$-dN(t) = N_{\mu^+} \left( \frac{1}{\tau_{\mu}} e^{-t/\tau_{\mu}} + \frac{1}{\tau_{\text{eff}}} \cdot \frac{1}{f} e^{-t/\tau_{\text{eff}}} \right) dt. \quad (14)$$

## 2.2 Cosmic Rays

The cosmic radiation represents a rich and at the same time inexpensive source for muons detection experiment. The primary cosmic radiation, which mainly consists of high-energy protons, extended particle showers are triggered on the upper layers of the atmosphere, which develop down to the ground. Initially, the result of interaction of the incident protons is often pions

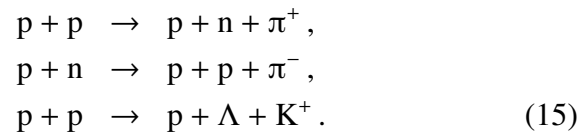

These then decay into muons

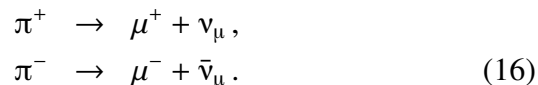

Since the atmosphere is about 28 radiation lengths or 12 nuclear interaction lengths thick, all (long-lived) particles with the exception of the muons (and neutrinos) are almost completely absorbed and rarely reach the ground. The mean energy loss  $dE/dX$  of muons is about  $2 \text{ MeV} \cdot \rho/\text{gcm}^2$  ( $\rho$ ). In the vicinity

of the earth's surface it applies to air  $dE/dX = 250 \text{ MeV km}^{-1}$ . In contrast to electrons, bremsstrahlung does not play a role in the considered energy range of the muons. The flow of muons at sea level is about  $200 \text{ m}^{-2} \text{ s}^{-1}$ . Since cosmic rays depend on the zenith angle  $\theta$  it has to penetrate atmospheric layers of different thicknesses, this leads to an angle dependence of the muon flow such as  $\cos^2\theta$ . There are slightly more positive muons than the negative ones; As already mentioned, the ratio is 1.270(3). The pulse spectrum of the muons from cosmic rays, measured at vertical incidence, is shown in Fig. 1. The maximum of the distribution is below 1, and the distribution drops steeply with increasing momentum. The mean energy of the muons at sea level is around 2–2.5 GeV.

In addition to the muons, neutrons and fast protons or pions also appear in the showers of cosmic rays. Figure 2 contains predictions for the relevant shares or their flows.

## 3 Experimental setup

The experimental setup is shown schematically in Fig. 3. The muons first pass through an approx. 10 cm thick lead absorber, which is used to shield other particles, and are then registered by means of the scintillator SC1. This and the two other scintillators have an area of  $50 \text{ cm} \times 30 \text{ cm}$ . In the following, 6 cm thick aluminium block, the muons are stopped further in order to decay and disintegrate as slowly as possible. When decaying, the muons or their decay products electron / positron is detected by the surrounding detectors SC2 and SC3, which consist of plates of scintillator material. The decay process is characterised by a simultaneous signal (coincidence) in detectors SC1 and SC2 (occurring simultaneously within the framework of detector resolution), followed by one by several  $\mu\text{s}$  delayed signal in SC2

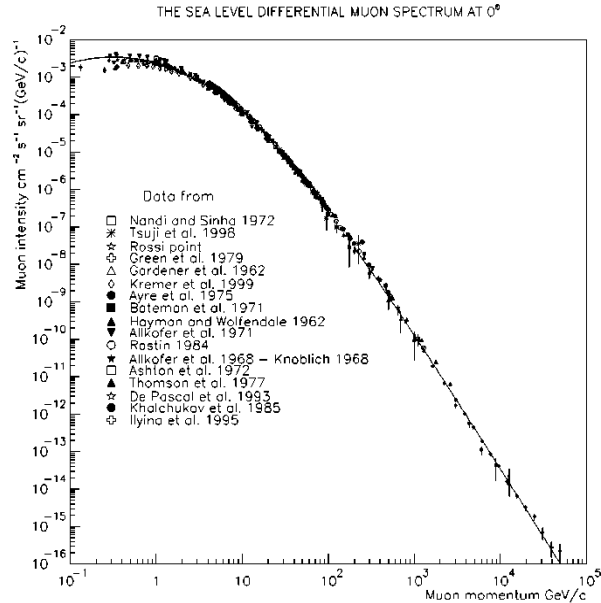

Figure 1: Different measurements of the momentum spectrum of muons from cosmic rays at sea level for different magnetic latitudes [8].

or SC3. The time differences between arrival and decay of the muons are to be measured and histogrammed.

All scintillators used here are NE102A plastic scintillators, which are connected to H7360-02 type photomultipliers from Hamamatsu (see Appendix C) via light guides made of Plexiglas. In addition to the high voltage supply, they also contain an amplifier and a discriminator for the output signals. The latter is used to suppress noise signals, which are usually caused by the thermal emission of electrons in the photocathode of the photomultiplier, and which usually have significantly lower pulse heights than those to be measured. the signals. In addition, the scintillators SC2 and SC3 are equipped with photomultipliers

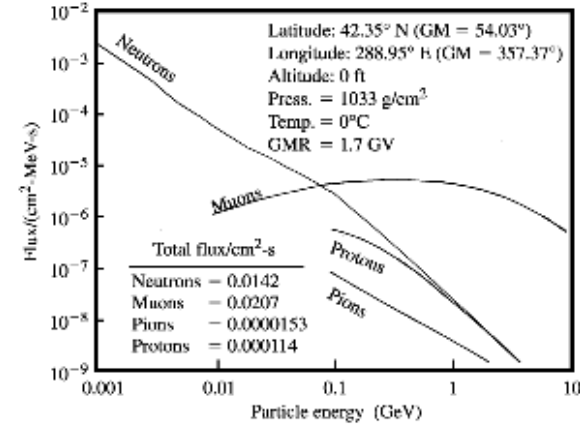

Figure 2: Forecast for the fluxes of the different types of particles in cosmic rays at sea level depending on their energy. The integrated flows are also given.

on both sides (left / right) for further noise suppression. This allows signals from the spontaneously emitted thermal electrons effectively suppress, since such signals occur in the left and right photomultiplier with no correlation in time. The output signals of the photomultiplier meet the TTL standard and are fed to the further readout electronics via coaxial cables. The available electronic modules are listed in Appendix B.

## 4 First day of the experiment: guide

### 4.1 Commissioning

For all circuits, it is important to ensure that signal cables are terminated with the appropriate impedance if necessary. Especially in the warm season, please remember to switch on the fan to cool the readout electronics during the measurements. The switch for

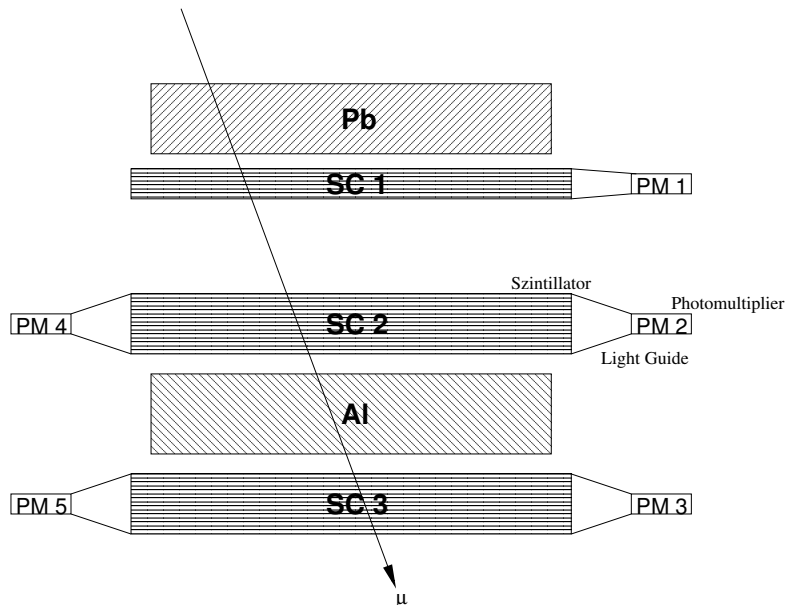

Figure 3: Detector arrangement for measuring the muon lifetime

this is located on the left-hand side at the base of the NIM crate. The power supply for the photomultiplier is switched on with the five green buttons on the left. Furthermore, the signals from the photomultiplier must be brought from TTL level to NIM standard. This is done using a *level converters*. Make sure that the corresponding toggle switch of the converter is in the COMPL position so that the NIM signals have the correct polarity.

## 4.2 Runtime behaviour of signals

When measuring such a short time difference, in addition to the mean lifetime of the muon, it is important to be clear about the runtime behaviour of the signals within the circuit and to recognise possible influences on the measurement.

**Exercise 4.2a:** Use the oscilloscope to measure the delay time of any coincidence unit. Use pulses from the scintillator block SC2 as input signals (ie PM2 and PM4 in coincidence).<sup>2</sup> Find a suitable circuit for measuring the delay of a coincidence unit and implement it. If the oscilloscope is running you can choose this address in a browser (<http://10.20.0.102>) to get a screenshot of the oscilloscope's display and you can use the windows snipping tool to save this screenshot.

## 4.3 Determination of the event rates

The following two tasks must be completed at the same time in order to save time.

**Exercise 4.3a:** Determine the event rates in the photo multiplier 1-5 first individually and then for coincidences in PM2 and PM4 or PM3 and PM5. Use the *quad scaler*. Measure at least four times each and average your result appropriately. Enter the mean value and the error in a table of measured values. How many lost of efficiency do you receive for the scintillators SC2 and SC3 when a left / right coincidence is required?

Also measure the rates for the coincidences  $SC1 \wedge SC2$ ,  $SC1 \wedge SC2 \wedge SC3$ ,  $SC1 \wedge SC2 \neg SC3$ ,  $SC2 \wedge SC3$  and  $SC2 \vee SC3$ . The measurement of the rates in the individual scintillators alone is also important, ie.  $SC1 \neg SC2 \neg SC3$ ,  $\neg SC1 \wedge SC2 \neg SC3$  and  $\neg SC1 \neg SC2 \wedge SC3$ . Check that your rates are consistent with each other.

**Exercise 4.3b:** At the same time, watch the associated signals on the oscilloscope with a reasonable time base of 20–400 ns, and for each configuration save at least one picture.

<sup>2</sup>This prevents unwanted interference signals in the oscillograms due to the noise suppression.



Use both input channels of the oscilloscope and, if necessary, the input for external triggering. Include all images and their meaningful interpretation in your report. How often do you see multiple hits on a channel?

#### 4.4 Time calibration

In order to be able to measure the muon lifetime, the output signal of the *time amplitude converters* (TAC) has to be calibrated before hand. For this purpose, according to the circuit in Fig. 4, using a coincidence unit and the *dual timer* create a Fanout in which pulses are duplicated and delayed by a variable delay element (*delay*), and then stopped at the TAC. The input pulse is now generated using the END MARKER output of the pulse generators of the *dual timer*. The signal starts the output of a pulse with a preset length  $\Delta t$  on the generator. Set the measuring range of the TAC from 0 to 20  $\mu\text{s}$ .

**Exercise 4.4a:** Observe the analog output signal of the TAC on the oscilloscope. How wide is this signal and how long is its delay compared to the STOP signal? Use the second channel on the oscilloscope to set a delay of exactly 3  $\mu\text{s}$ . Does the level of the TAC output signal meet your expectations? Enter the oscillogram in your protocol!

The set delay is related to the output voltage of the TAC, which is determined by means of the multi channel analyzers (MCA) is visible on the PC. Due to the finite resolution of the ADC (Analog-to-Digital Converter), several channels can respond at the same time, the width of this distribution being a measure of the time resolution of the circuit

**Exercise 4.4b:** Create by measuring at around 15-20 various time delays relevant for the subsequent experiment, a calibration which indicates the relationship between the time

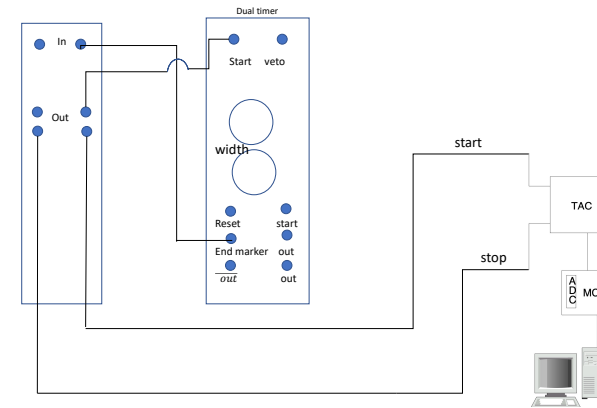

Figure 4: Block diagram for determining the time calibration

interval and the ADC channel. It is essential to set the times precisely using the oscilloscope. A simple reading of the setting scale of the *delay* is not sufficient here, as this has a strong non-linear behavior, especially at the lower end of the setting range. For starting the *dual timer* use the start key. Enter all measurements in *single* Spectrum and save it. This is then evaluated on the second day of the experiment. Do not forget to note down the set delay times for each measurement in the correct order.

#### 4.5 Measurement of the muon lifetime

The muon lifetime is measured using the circuit in Fig. 5. A muon entering from above, which decay in the aluminium layer of the detector, initially only triggers signals in scintillators SC1 and SC2, but not in SC3. Such a signature starts the timing of the TAC. In the subsequent decay of the muons to  $e^\pm$ , there are basically two possibilities: (1) The  $e^\pm$  is emitted in the forward direction

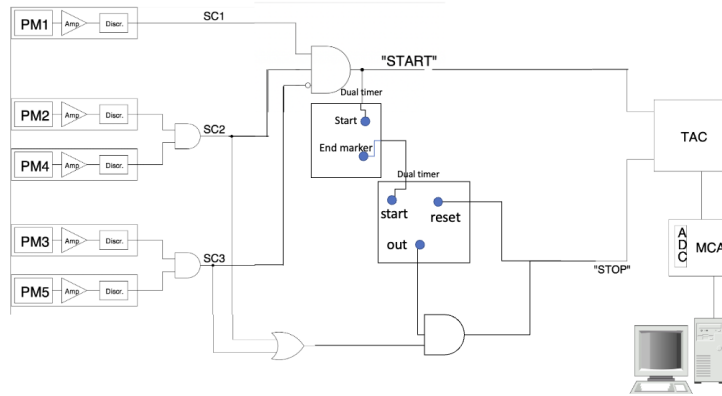

Figure 5: Determination of the muon lifetime

and is therefore detected in the scintillator SC3 but not in SC2 or SC1. (2) The  $e^\pm$  that travel in the reverse direction are possibly also registered in SC1 and SC2. In this case, the scintillator SC3 must not generate a signal. If one of the two decay signatures occurs, the time measurement by the TAC is stopped and the measured time period is passed on to the MCA, where it is saved and histogrammed. Since the photomultipliers used in this experiment are very sensitive, a large number of background events are recorded, which interfere with the measurement. In order to eliminate at least part of the subsurface, all STOP signals are discarded, which occur within a time window of  $3 \mu\text{s}$  after the received START signal. In order to create proper delay and reset it every time one signal is accepted, two *dual timer* must be used. With the first *dual timer* a delay of  $3 \mu\text{s}$  created between the START and STOP signal. The output of END MARKER from the first *dual timer* generates a pulse which is fed to the start of the second *dual timer* creating a time interval of  $17 \mu\text{s}$  in which the pulses are accepted. Then the output of the timer is fed to

the STOP of TAC. If the first delay interval is  $D1$  and the time interval of second *dual timer*  $T1$ , the final time interval in the output is  $[D1, (D1+T1)]$ . At the end the STOP signal of TAC is  $T1 \wedge (SC2 \vee SC3)$ . Noted that the output of second timer must be reset the delay  $D1$  every time there is a signal accepted in  $T1$ .

**Exercise 4.5a:** Take the spectrum first *without* the Set up the delay circuit for about 30 min and verify the need for a delay of  $3 \mu\text{s}$ . Enter the recorded spectrum in your protocol and interpret it!

**Exercise 4.5b:** Now measure with the  $3 \mu\text{s}$   $D1$  and a time interval of  $17 \mu\text{s}$  for  $T1$  and -suppression over a longer period of time (several hours or days) and collect enough decay times so that the expected exponential decay spectrum becomes visible on the MCA, from which the decay time of the muon can be determined. Also determine the rate of the registered muon decays, and roughly estimate the measuring time, which is necessary to be able to determine the mean lifetime with an accuracy of 1 %.

## 5 Second day of the experiment: evaluation

The aim of the evaluation is to extract the mean muon lifetime from the recorded spectrum of decay times and to determine the associated statistical and systematic error. A Jupyter notebook is available for statistical analysis of the measurement data. Connect to the NotebookServer using a web browser and upload the template files. The Notebook file is `muonfit.ipynb`.

## 5.1 calibration curve

First, the results of the time calibration are used to determine the calibration line by means of a fit. So that's the one functional relationship between the channel number of the MCA and the time measurement of the TAC known.

**Exercise 5.1a:** Measure the positions and width of the peaks in your calibration spectrum. Enter your results together with the set delay times in a table in your report. Create a diagram from the time channel value pairs and their statistical errors. Do a fit with it to get the calibration curve. Enter both the diagram and the results of the fit (including the  $\chi^2$ -Value!) In your report. How well the assumption of a linear relationship is fulfilled?

## 5.2 Rebinning

The range of lifetime should be considered before the fit, one should do *rebinning* i.e. several adjacent channels (*bins*) summed in one bin.

**Exercise 5.2a:** Perform a suitable rebinning of the calibrated decay spectrum. Justify your choice of rebinning.

## 5.3 Determination of the mean lifetime

Using a  $\chi^2$ - determine the mean lifetime in accordance with the muon decay law developed in Section 2.1. Keep in mind that there are still background events in your spectrum.

**Exercise 5.3a:** Think about how background events can influence the decay spectrum. Your results from section 4.3 may help you here. What types of background do you expect? Develop one or more models to describe it in your spectrum.

**Exercise 5.3b:** Now use  $\chi^2$ - determine the mean muon lifetime using your data . Enter the spectrum with the superimposed fit function as well as the values and statistical uncertainties of all parameters in the report. Explain your procedure (settings for start values of parameters, parameters kept in bold, etc.). Also comment on the quality of the fit.

Note that  $\tau_{\text{eff}}$  is from  $\tau_{\mu}$  and should therefore not appear as a parameter of the model.

## 5.4 Systematics

Like any other experiment, this experiment is not free from systematic influences. These need to be investigated.

**Exercise 5.4a:** Determine quantitatively the influence of the uncertainties in the parameters  $f = N_{\mu^+}/N_{\mu^-}$  and  $\Lambda_C$  on your measurement result. Discuss other possible systematic sources of error and quantify them. Put it *all* combine results in a table or diagram and comment on them. Determine the total systematic error of the measurement from the significant proportions.

## 5.5 Final result

**Exercise 5.5a:** Enter your mean lifetime of the muons including the statistical and systematic uncertainties. Compare with the current one from Literature value by calculating the confidence level of your result.

## A For calculating the muon flow

The flux of cosmic rays at sea level is at normal incidence

$$j(\theta=0, \phi) = 110 \text{ m}^{-2} \text{ s}^{-1} \text{ sr}^{-1}. \quad (17)$$

This results in the flux dependent on the polar angle

$$\begin{aligned} j(\theta, \phi) &= 110 \text{ m}^{-2} \text{ s}^{-1} \text{ sr}^{-1} \cdot \cos^2\theta \\ &= 0.66 \text{ m}^{-2} \text{ s}^{-1} \text{ sr}^{-1} \cdot \cos^2\theta. \end{aligned} \quad (18)$$

The integration over all solid angles in the range  $0 < \theta < \pi/2$  and  $0 < \phi < 2\pi$  then read

$$\begin{aligned} \int_{2\pi} j(\theta, \phi) \cos\theta \, d\Omega &= 0.66 \cdot \int_{\theta=0}^{\pi/2} \int_{\phi=0}^{2\pi} \cos^3\theta \sin\theta \, d\theta \, d\phi \\ &= -0.66 \cdot \int_{\theta=0}^{\pi/2} \int_{\phi=0}^{2\pi} \cos^3\theta \, d\cos\theta \, d\phi \\ &= 1.04 \text{ cm}^{-2} \text{ min}^{-1} = 173.3 \text{ m}^{-2} \text{ s}^{-1}. \end{aligned} \quad (19)$$

The additional  $\cos\theta$ - Term from the fact that a cosmic particle which is at an angle  $\theta$  runs in, sees the horizontal surface of the detector shortened by this same factor.

## B List of NIM modules used

- LeCroy NIM Model 688 AL Level Adapter (TTL/NIM)
- LeCroy NIM Model 460B Triple 4-Fold Logic Unit
- LeCroy NIM Model 465 4-fold coincidence
- LRS NIM Model 622C Quad 2-Fold Logic Unit
- CAEN Dual Timer Model N93B

- CAEN Quad Scaler and Preset Counter/Timer Model N145
- Ortec TAC/SCA Model 567

# C Datasheet of the Hamamatsu photomultiplier

## Head-on PMT Photon Counting Head H7360 Series

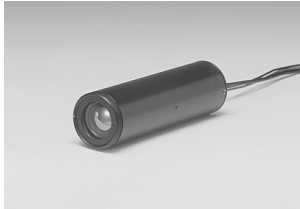

The H7360 series is a wide sensitive area photon counting head device containing a 25-mm (1") head-on photomultiplier tube, high-voltage power supply circuit and photon counting circuit. Since those circuits are designed for wide band, the H7360 series can operate at a high count rate. The high voltage supply for photomultiplier tube and the discriminator level are preset to optimum values so that photon counting can be performed just by connecting a +5 V supply and a pulse counter.

The H7360-01 is of low noise, the H7360-02 has enhanced detection efficiency in the visible range, and the H7360-03 covers sensitivity from the visible to near infrared.

A mount flange (E6264) is provided as an option for easy installation to measurement equipment.

### Product Variations

Type No.	Spectral Response	Features
H7360-01	300 nm to 650 nm	Low noise
H7360-02	300 nm to 650 nm	High detection efficiency
H7360-03	300 nm to 850 nm	For visible to near IR range

### Specifications

Parameter		H7360 Series			Unit	
		-01	-02	-03		
Suffix		-01	-02	-03		
Input Voltage		+4.75 to +5.25			V	
Max. Input Voltage		+6			V	
Max. Input Current		140			mA	
Effective Area		φ22			mm	
Peak Sensitivity Wavelength		375	420	420	nm	
Count Sensitivity	Typ.	300 nm	$1.4 \times 10^5$	$2.3 \times 10^5$	$2.1 \times 10^5$	$s^{-1} \cdot \mu W^{-1}$
		400 nm	$2.7 \times 10^5$	$4.1 \times 10^5$	$2.5 \times 10^5$	
		500 nm	$1.7 \times 10^5$	$3.4 \times 10^5$	$2.0 \times 10^5$	
		600 nm	$4.6 \times 10^4$	$5.7 \times 10^4$	$1.3 \times 10^5$	
		700 nm	—	—	$7.8 \times 10^4$	
Count Linearity *1		$6.0 \times 10^6$			$s^{-1}$	
Dark Count *2	Typ.	15	60	5000	$s^{-1}$	
	Max.	80	300	15000		
Pulse-pair Resolution		18			ns	
Output Pulse Width		9			ns	
Output Pulse Height *3	Typ.	3			V	
Recommended Load Resistance		50			Ω	
Signal Output Logic		Positive logic			—	
Operating Ambient Temperature		+5 to +40			°C	
Storage Temperature		-20 to +50			°C	
Weight	Main Body	140			g	
	Mount Flange	25				

\*1: Random pulse, at 10 % count loss

\*2: After 30 minute storage in darkness

\*3: With input voltage +5 V, Load resistance 50 Ω and Coaxial cable RG-174/U (450 mm)

## Photon Counting Heads

### Characteristics (Count sensitivity, Dark count)

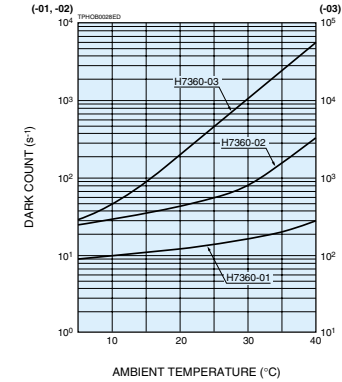
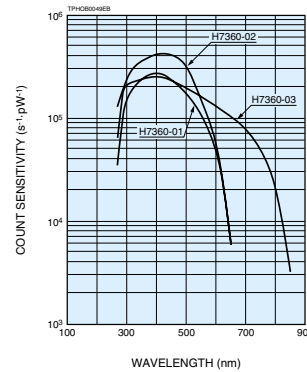

### Block Diagram

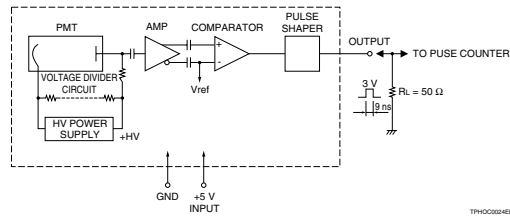

### Dimensional Outlines (Unit: mm)

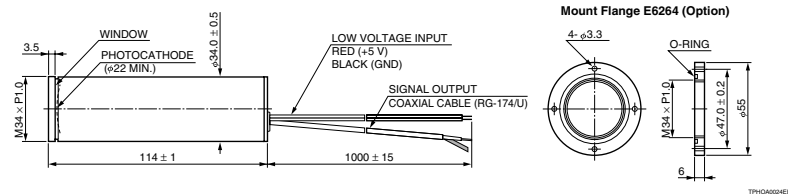

# Contents

<b>1</b>	<b>General preliminary remarks</b>	<b>2</b>
1.1	Implementation . . . . .	2
1.2	Previous knowledge . . . . .	2
1.3	List of questions (exemplary) . . . . .	3
1.3.1	Muon decay . . . . .	3
1.3.2	Detectors . . . . .	3
1.3.3	Switching electronics . . . . .	3
1.3.4	Statistics . . . . .	3
1.4	Preparatory tasks . . . . .	3
<b>2</b>	<b>Introduction</b>	<b>4</b>
2.1	Electroweak theory and muon decay . . . . .	4
2.1.1	Muonic Atoms and Nuclear Capture . . . . .	5
2.2	Cosmic Rays . . . . .	6
<b>3</b>	<b>Experimental setup</b>	<b>6</b>
<b>4</b>	<b>First day of the experiment: guide</b>	<b>7</b>
4.1	Commissioning . . . . .	7
4.2	Runtime behaviour of signals . . . . .	8
4.3	Determination of the event rates . . . . .	8
4.4	Time calibration . . . . .	9
4.5	Measurement of the muon lifetime . . . . .	9
<b>5</b>	<b>Second day of the experiment: evaluation</b>	<b>10</b>
5.1	calibration curve . . . . .	11
5.2	Rebinning . . . . .	11
5.3	Determination of the mean lifetime . . . . .	11
5.4	Systematics . . . . .	11
5.5	Final result . . . . .	11
<b>A</b>	<b>For calculating the muon flow</b>	<b>12</b>

<b>B</b>	<b>List of NIM modules used</b>	<b>12</b>
<b>C</b>	<b>Datasheet of the Hamamatsu photomultiplier</b>	<b>13</b>

## References

- [1] W.R. Leo. Techniques for Nuclear and Particle Physics Experiments. Springer, 2nd edition, 1994.
- [2] Roger Barlow. Statistics. The Manchester physics series. Wiley, 1995.
- [3] Roger Barlow. SLUO Lectures on Statistics and Numerical Methods in HEP: Lecture 5: Systematic Errors. Manchester University, August 2000. <http://www.hep.man.ac.uk/u/roger/sluo5.ps>
- [4] Siegmund Brandt. Datenanalyse. Spektrum Akademie Verlag, 4th edition, 1999.
- [5] David Griffiths. Introduction to Elementary Particles. Wiley & Sons, 1987.
- [6] Claus Grupen. Teilchendetektoren. BIWissenschaftsverlag, 1993.
- [7] Francis Halzen and Alan D. Martin. Quarks and Leptons. Wiley & Sons, 1984.
- [8] J. Kempa. The muon energy spectra at various geomagnetic latitudes. In 29th International Cosmic Ray Conference, volume 6, pages 57–60, Pune, India, 2005.
- [9] Konrad Kleinknecht. Detektoren für Teilchenstrahlung. Teubner, 4th edition, 2005.
- [10] T Suzuki, David F Measday, and JP Roalsvig. Total nuclear capture rates for negative muons. Phys. Rev. C, 35(6):2212, 1987.
- [11] Blobel V and E. Lohrmann. Statistische und numerische Methoden der Datenanalyse. Teubner, Stuttgart, 1998.
- [12] W.-M. Yao et al. Review of Particle Physics. Journal of Physics G, 33, 2006. <http://pdg.lbl.gov>.